

G4011A-05-A-NC
MINI MULTIPLE DOWNLIGHT

| | | | |
|------------------|--|--------------------|------------|
| Catalog # | | Prepared by | LiteHarbor |
| Project | | Date | |
| Notes | | | |

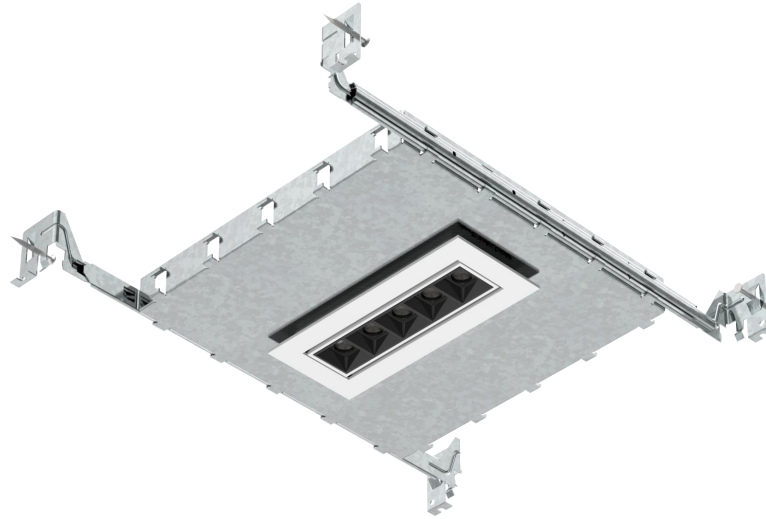

MINI MULTIPLE DOWNLIGHT

New Construction Adjustable Mini LED Multiple Downlight with 5 Lamps

Description

The Mini Multiple Downlight Series is equipped with 5, 10 and 15, 5x2, 10x2, 15x2 lamps. The miniaturized design, die-cast aluminum body, and high-performance acrylic diffuser provide uniform scientific light output for maximum visual comfort. Recessed rectangular luminaire with LEDs. Shaped steel sheet structural compartment with outer rim. The N*5 lighting cells linear body, in die-cast aluminium, can be used to direct the emission with a tilting adjustability of +/- 30 °. Metallised thermoplastic high definition optics, integrated in a rear position in the black anti-glare screen; the structure of the optical system prevents a pinpoint effect, allowing precise, circular light distribution and emission with controlled luminance.

Features

- The simplified retrofit installation can be used in both new and existing spaces.
- Dimmable with a variety of commonly used drivers.
- Life Rated for 50,000 hours at 70% lumen maintenance.
- Easy installation for new construction and remodel applications.

Specification

- Luminaire efficacy: 60 to 80lm/W
- Source: White LED module (LM-80 tested) 2700K~6000K CRI>90



Liteharbor Lighting Technology Co., Ltd.
 New Industry Area Hecun Danzao Town
 Nanhai Foshan City Guangdong China

TEL: +86-757-8180 8687
 FAX: +86-757-8180 8685
 E-mail: info@liteharbor.com

Website: www.liteharbor.com
 Specifications subject to change w/o notice
 Revision: Jun. 2019

- Lumen maintenance: 90% of initial lumens at 50 000 hours (L90) (LM79 tested)
- Optics: Low luminance: Spot optic, with pptibeam technology
- Material: Body and Heat sink: Die-cast aluminum, Reflector and Baffle: Thermoplastic
- Mounting: New construction installation or remodel installation
- Electrical: High efficiency electronic driver, rated at 50 000 hours
- Weight: 0.1 to 2.42lbs (0.05 to 1.1kg)
- Warranty: 3 year limited warranty.

Listing / Warranty

ETL listed to US and Canadian standards for damp location W/Feed through.

3 Year Limited Warranty.

Applications

Suitable for jewelry stores, boutiques, luxury goods stores, shopping malls and other places that require concentrated lighting and accent lighting.

Parameter

| | |
|----------|--------------------|
| Wattage | 2W/Lamp |
| Lumen | 60-80lm/W |
| Optics | 30° |
| CCT | 2700K ~ 6000K |
| Material | Die-cast Aluminum |
| Dimming | Non/TRIAC/0~10V |
| Finish | White/Black/Silver |

Ceiling Cut Hole

| Lamp | 5 Lamp | 10 Lamps | 15 Lamps | 2X5 Lamps | 2X10 Lamps | 2X15 Lamps |
|--------------|--|---|---|--|--|--|
| Cut-out Size | 2 $\frac{1}{4}$ " x 6 $\frac{1}{16}$ " (57x155mm) | 2 $\frac{1}{4}$ " x 11 $\frac{5}{16}$ " (57x288mm) | 2 $\frac{1}{4}$ " x 16 $\frac{1}{2}$ " (57x 419mm) | 5 $\frac{7}{16}$ " x 5 $\frac{1}{2}$ " (140x 155mm) | 5 $\frac{7}{16}$ " x 11 $\frac{5}{8}$ " (140x288mm) | 5 $\frac{7}{16}$ " x 16 $\frac{1}{2}$ " (140x419mm) |



Liteharbor Lighting Technology Co., Ltd.
 New Industry Area Hecun Danzao Town
 Nanhai Foshan City Guangdong China

TEL: +86-757-8180 8687
 FAX: +86-757-8180 8685
 E-mail: info@liteharbor.com

Website: www.liteharbor.com
 Specifications subject to change w/o notice
 Revision: Jun. 2019

Dimensions

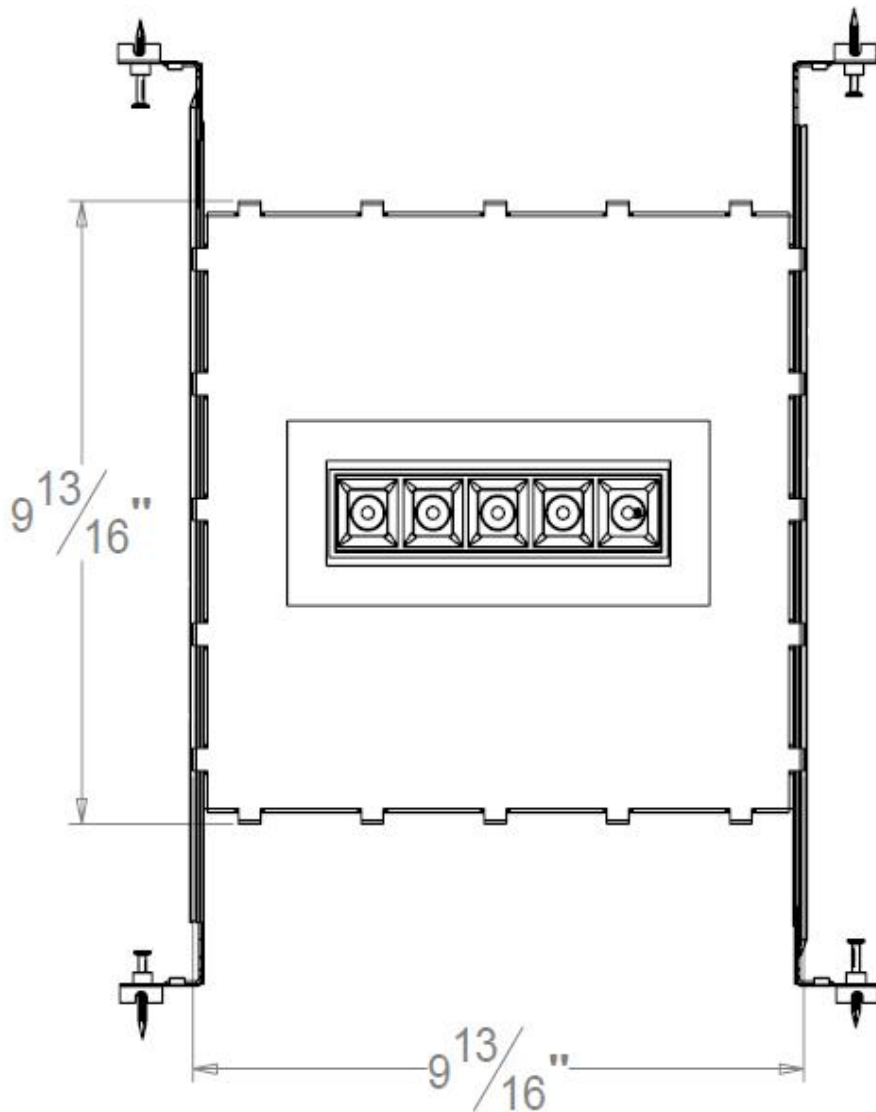
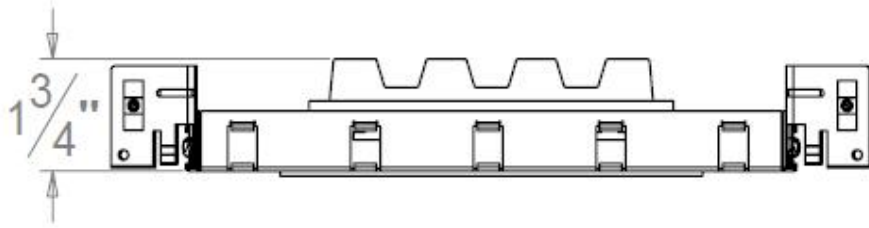

MINI MULTIPLE DOWNLIGHT



Liteharbor Lighting Technology Co., Ltd.
New Industry Area Hecun Danzao Town
Nanhai Foshan City Guangdong China

TEL: +86-757-8180 8687
FAX: +86-757-8180 8685
E-mail: info@liteharbor.com

Website: www.liteharbor.com
Specifications subject to change w/o notice
Revision: Jun. 2019

Ordering Guide

| Series/Lumen | Input Voltage | CCT/CRI | Dimming |
|---|--------------------------------------|------------------------------------|--|
| <input type="checkbox"/> G4011A-05-A-NC/720lm | <input type="checkbox"/> 120V | <input type="checkbox"/> 3000K/90+ | <input type="checkbox"/> Non-dimming |
| New Construction Mini | <input type="checkbox"/> 230V | <input type="checkbox"/> 4000K/90+ | <input type="checkbox"/> TRIAC Dimming |
| LED Multiple Downlight | <input type="checkbox"/> 277V | <input type="checkbox"/> 5000K/90+ | <input type="checkbox"/> 0~10V Dimming |
| | <input type="checkbox"/> 120-277V AC | | |

| Finish | Reflector |
|---------------------------------|---------------------------------|
| <input type="checkbox"/> White | <input type="checkbox"/> White |
| <input type="checkbox"/> Black | <input type="checkbox"/> Black |
| <input type="checkbox"/> Silver | <input type="checkbox"/> Chrome |
| | <input type="checkbox"/> Gold |

*Other special requirements please confirm with our factory



MINI MULTIPLE DOWNLIGHT

Notes:

1. In order to ensure normal operation of the product, please ensure that the voltage used is within the marked voltage range.
2. Please install and use the product in the correct way.
3. Please turn off the power to avoid the risk of electric shock when installing or removing product.
4. Do not look directly at LED light source for a long time, high intensity light source may cause eye injury.
5. If you find any of the following problems, please ask a qualified electrician for repair service. Do not disassemble it at will:
 - ① When the product produces odorous gas, abnormal sound or unusual flashing.
 - ② When the shell is damaged and foreign bodies invade the interior.



Liteharbor Lighting Technology Co., Ltd.

New Industry Area Hecun Danzao Town
Nanhai Foshan City Guangdong China

TEL: +86-757-8180 8687

FAX: +86-757-8180 8685

E-mail: info@liteharbor.com

Website: www.liteharbor.com

Specifications subject to change w/o notice

Revision: Jun. 2019